

2.40m x 2.40m Arc Window
 Use : 2.55m x 2.55m sun
 shade (3" border all around)

2.40m x 2.40m Arc Window
 Use : 2.55m x 2.55m sun
 shade (3" border all around)

2.40m x 2.40m Arc Window
 Use : 2.55m x 2.55m sun
 shade (3" border all around)

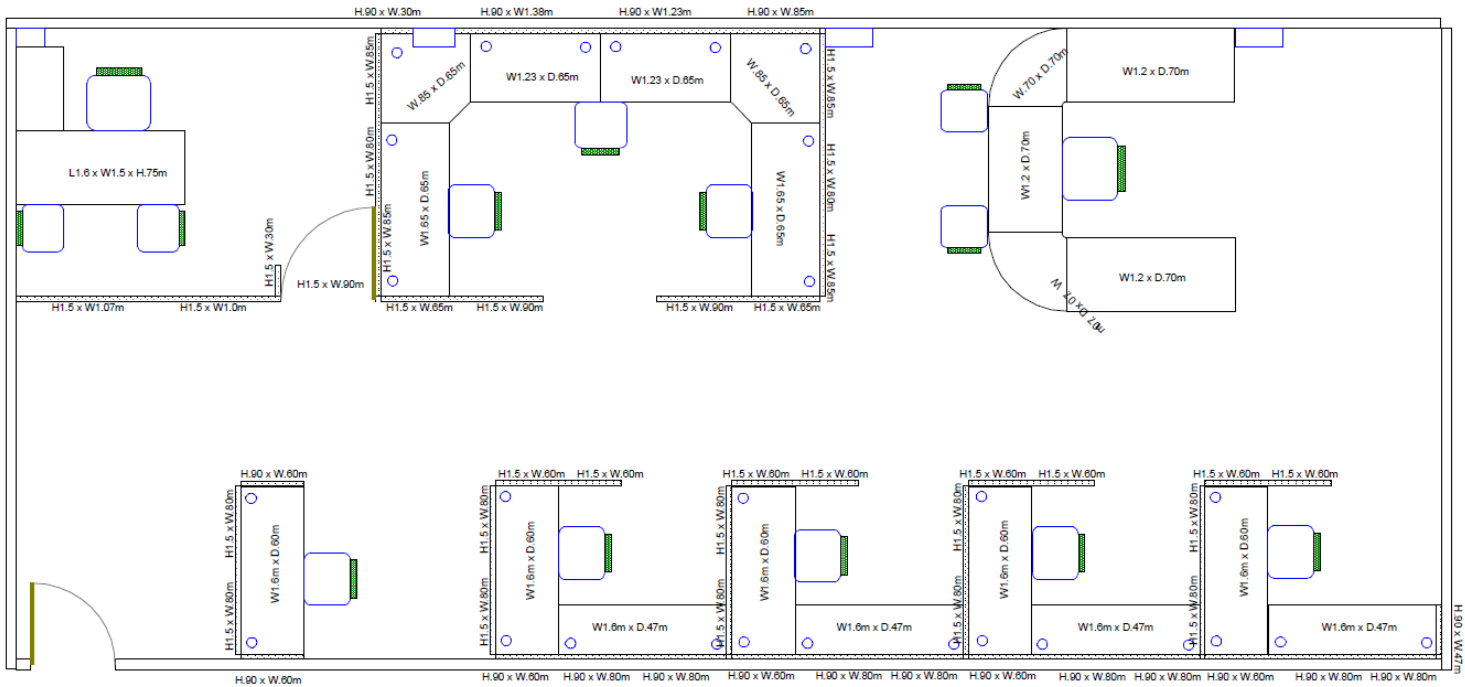

MIS OFFICE, 2ND FLOOR ADMIN. ANNEX BUILDING

1.20m x 2.40m Window
Use : 1.35m x 2.55m sun
shade (3" border all
around)

1.20m x 2.40m Window
Use : 1.35m x 2.55m sun
shade (3" border all
around)

1.20m x 2.40m Window
Use : 1.35m x 2.55m sun
shade (3" border all
around)

1.20m x 2.40m Window
Use : 1.35m x 2.55m sun
shade (3" border all
around)

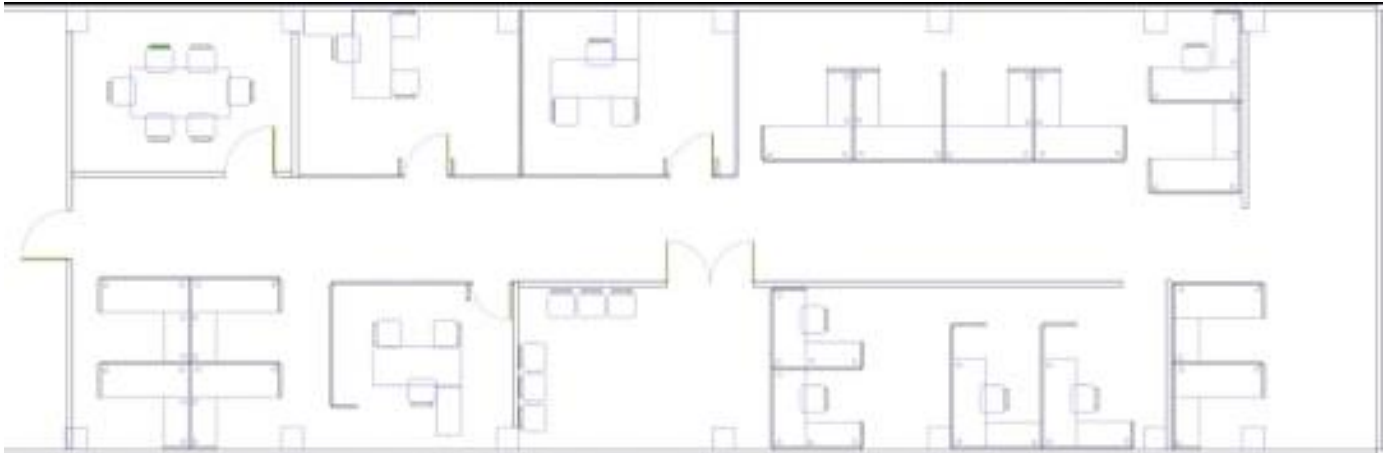

1.20m x 2.40m Window
Use : 1.35m x 2.55m sun
shade (3" border all
around)

1.20m x 2.40m Window
Use : 1.35m x 2.55m sun
shade (3" border all
around)

1.20m x 2.40m Window
Use : 1.35m x 2.55m sun
shade (3" border all
around)

1.20m x 2.40m Window
Use : 1.35m x 2.55m sun
shade (3" border all
around)

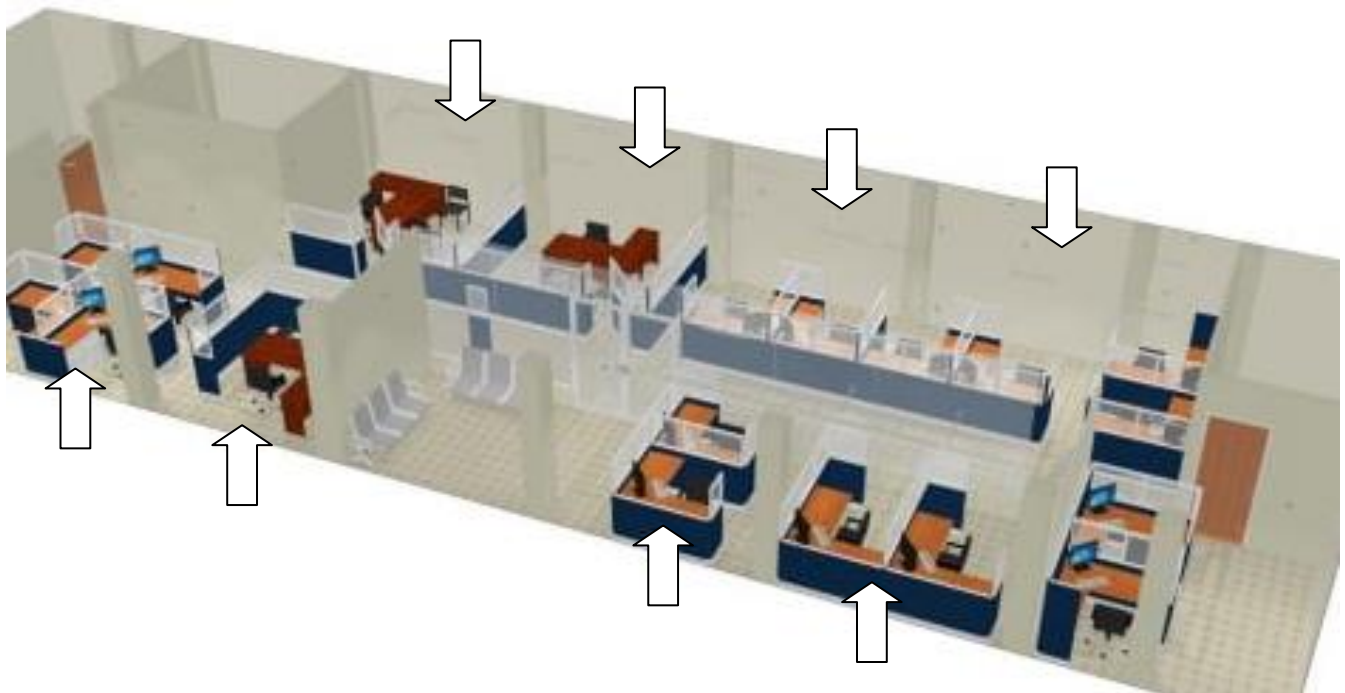

ACCOUNTING OFFICE, 1ST FLOOR ADMIN. ANNEX BUILDING

(2 TONE/COMBO SUN SHADE BLINDS)

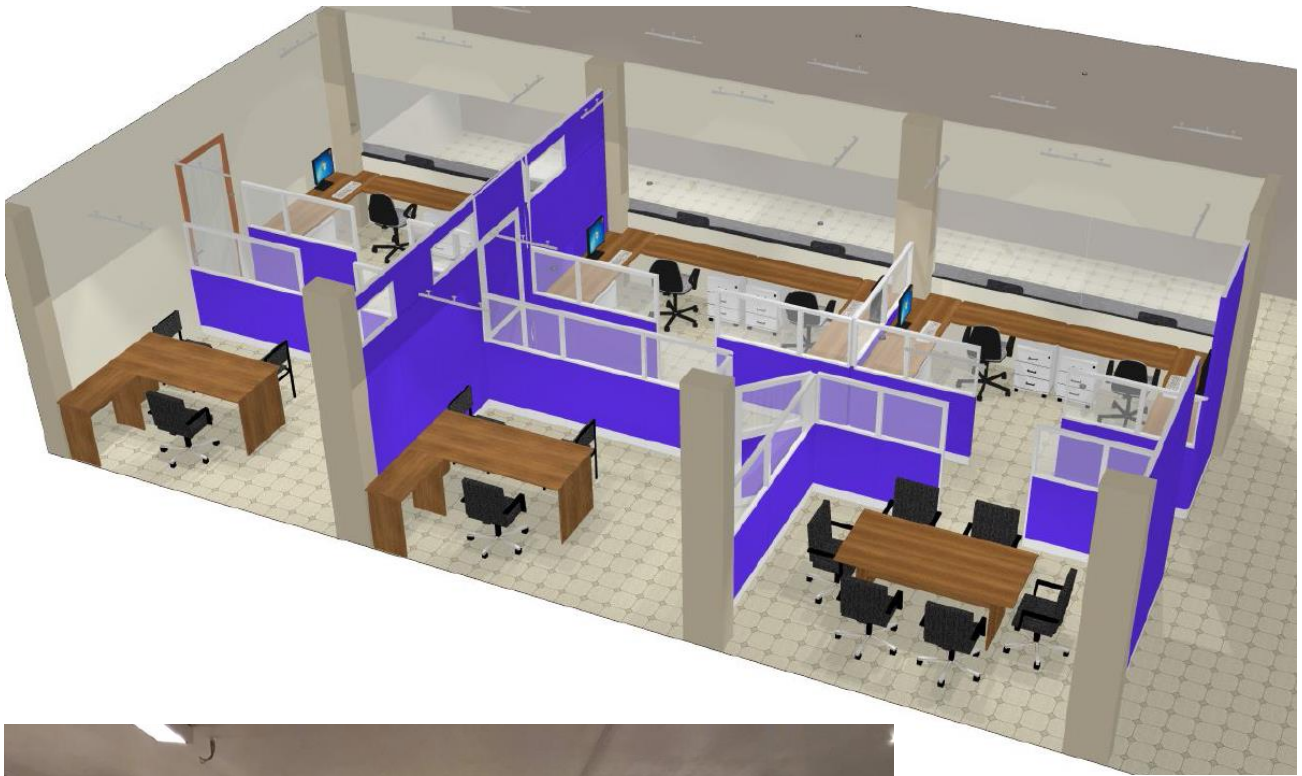
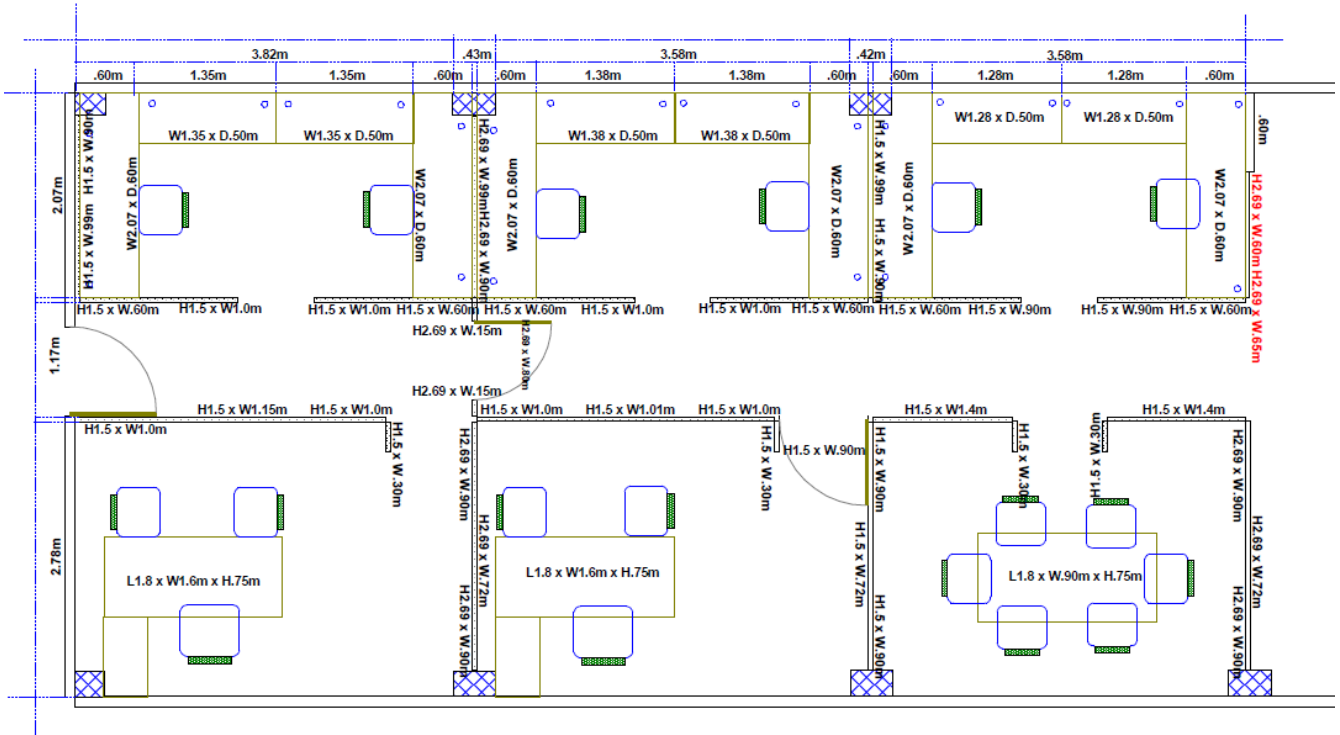

CASHIER'S OFFICE, 1ST FLOOR ADMIN. BUILDING

LOT II - VARIOUS FURNITURE AND FIXTURES



1 – Lateral Filing Cabinet



2 – Filing Cabinet



3 – Office Chair



4 – Executive Chair



5 – Executive Chair



6 – Guest Chair



7 – Executive Table

8 – Executive Table

COMPOSITION OF U-SHAPED TABLE



3pcs Table with 25mm melamine top with ducknose edge & w/ grommets
18mm legs with adjustable footings
L1.2 x W.70 x H.75m

1pc Mobile pedestal
Melamine materials

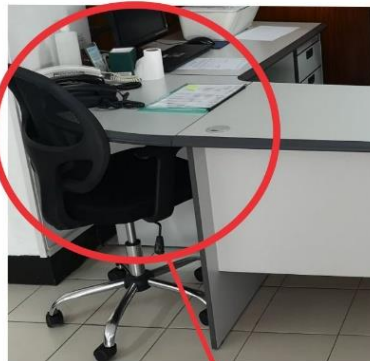

2pcs Quarter Round
table connector
with ducknose edge



9 – Office Chair



10 – Executive Chair



11 – Junior Chair



12 – Guest Chair



13 – L-Executive Table



14 – Mobile Pedestal



15 – CPU Holder



16 – Center Drawer



17 – Lateral Filing Cabinet



18 – Conference Table



19 – 4D Vertical Filing Cabinet



20 – Guest Chair

PARTITION DETAIL

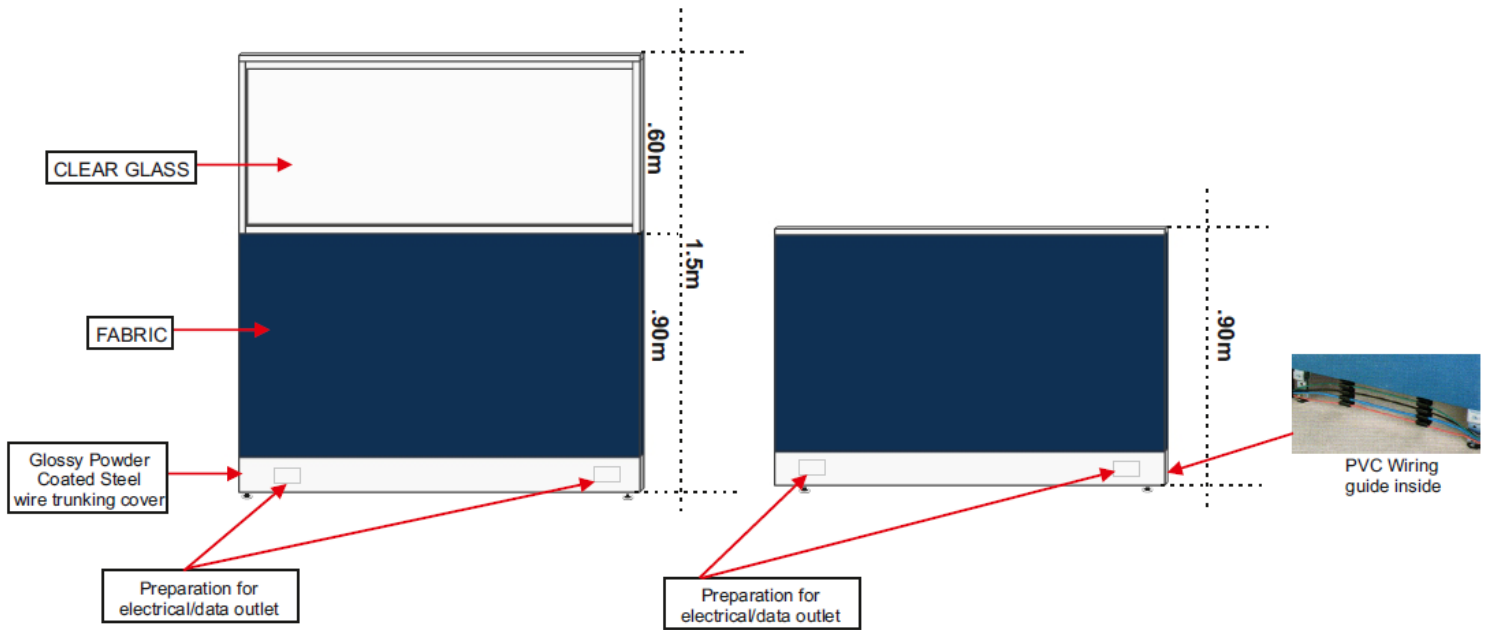

Handwritten signature